

PYPILOT was imagined and designed by Sean D'EPAGNIER
Thanks to him for this fantastic boat autopilot

NAVITOP.FR

Sheet: /
File: 15-controllerV3.2P.kicad_sch

Title: PYPilot MOTOR CONTROLLER 15A +CLUTCH OUTPUT by NaviTop

Size: A4 Date: 2025-04-24

KiCad E.D.A. 9.0.0

Rev: E

Id: 1/2

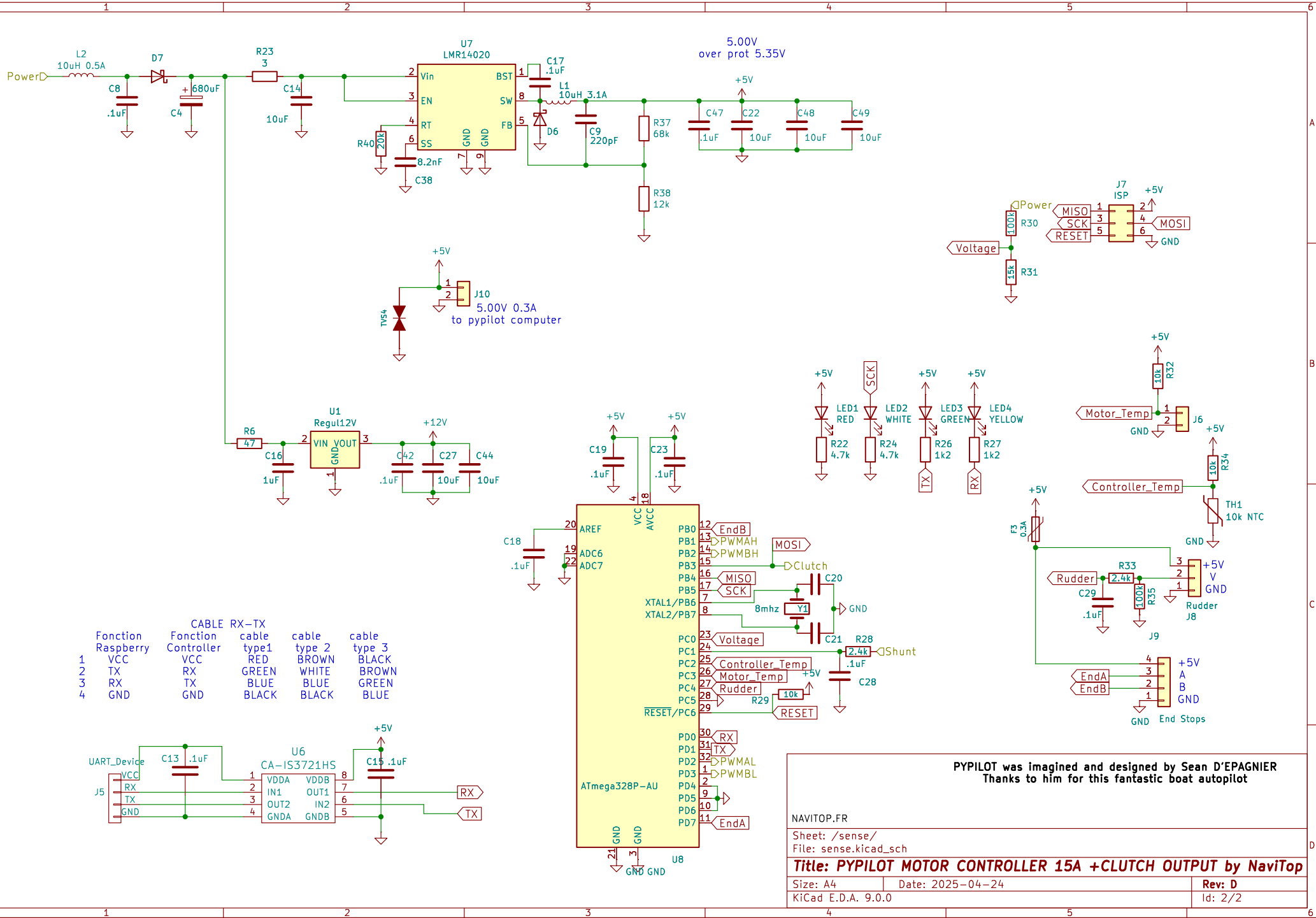

CABLE RX-TX

Fonction Raspberry	Fonction Controller	cable type1	cable type 2	cable type 3
1 VCC	VCC	RED	BROWN	BLACK
2 TX	RX	GREEN	WHITE	BROWN
3 RX	TX	BLUE	BLUE	GREEN
4 GND	GND	BLACK	BLACK	BLUE

PYPILOT was imagined and designed by Sean D'EPAGNIER
 Thanks to him for this fantastic boat autopilot

NAVITOP.FR
 Sheet: /sense/
 File: sense.kicad_sch

Title: PYPILOT MOTOR CONTROLLER 15A + CLUTCH OUTPUT by NaviTop

Size: A4	Date: 2025-04-24	Rev: D
KiCad E.D.A. 9.0.0		Id: 2/2